



**GAUTENG PROVINCE**  
EDUCATION  
REPUBLIC OF SOUTH AFRICA

**PROVINCIAL EXAMINATION**  
**JUNE 2022**  
**GRADE 10**

**PHYSICAL SCIENCES (PHYSICS)**  
**(PAPER 1)**

**TIME: 1 hour**

**MARKS: 100**

**11 pages and 2 formula sheets**

### **INSTRUCTIONS AND INFORMATION**

1. Write your name in the appropriate space on the ANSWER BOOK.
2. This question paper consists of 6 questions. Answer ALL the questions.
3. Start EACH question on a NEW page in the ANSWER BOOK.
4. Number the answers correctly according to the numbering system used in this question paper.
5. You may use a non-programmable calculator.
6. You may use appropriate mathematical instruments.
7. USE the DATA SHEETS that are attached.
8. Show ALL formulae and substitutions in ALL calculations.
9. Round off your FINAL numerical answers to a minimum of TWO decimal places.
10. Write neatly and legibly.

**QUESTION 1: MULTIPLE-CHOICE QUESTIONS**

Four options are provided as possible answers to the following questions. Each question has only ONE correct answer. Choose the answer and write only the letter (A – D) next to the question numbers (1.1 to 1.8) in the ANSWER BOOK, e.g. 1.9 E.

1.1 Four physical quantities are given below:

- i Acceleration
- ii Velocity
- iii Speed
- iv Displacement

Which of the following is the CORRECT combination for a vector and a scalar?

- A i and ii
- B i and iii
- C ii and iv
- D i and iv

(2)

1.2 Which of the following graphs best describes the relationship between the gravitational potential energy and the height of an object?

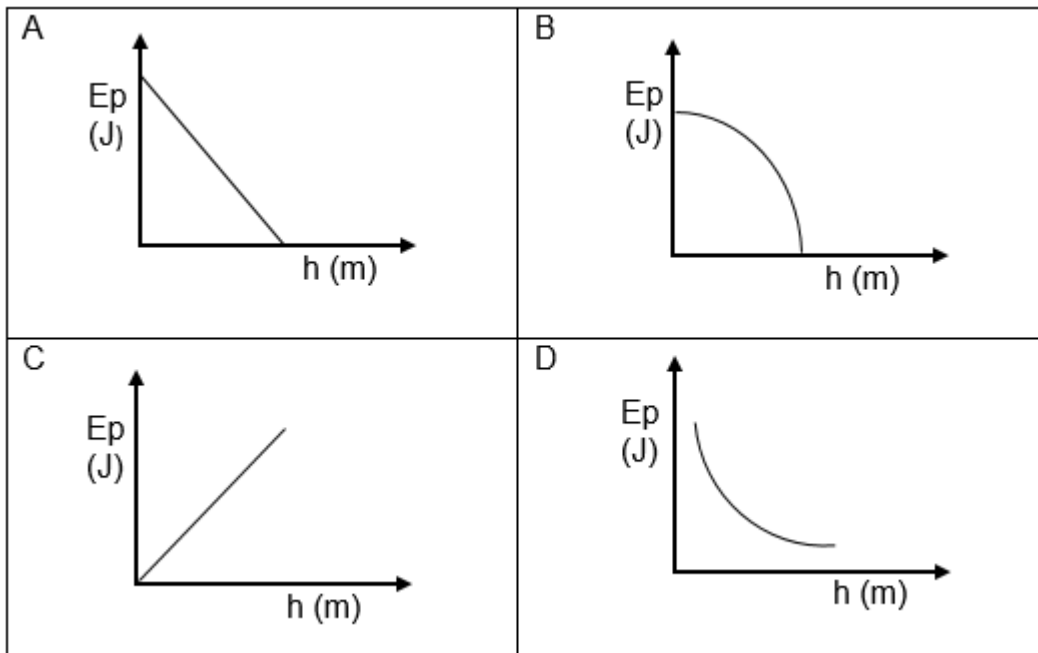

(2)

- 1.3 A block of mass  $m$ , slides across a frictionless inclined plane **RS** as shown below. Ignore the effects of air resistance.

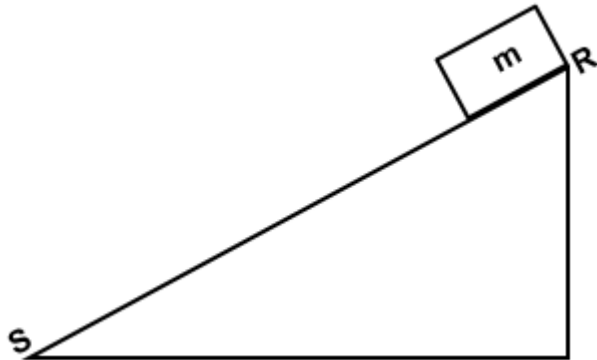

Which of the following about the mechanical energy (EM) of the block is CORRECT?

- A  $(EM)_R > (EM)_S$
- B  $(EM)_R = (EM)_S$
- C  $(EM)_R < (EM)_S$
- D  $(EM)_R = 0$

(2)

- 1.4 Two identical metal spheres, **Y** and **Z**, are suspended from long silk threads as shown in the diagram below. The sphere **Y** carries an UNKNOWN positive charge while sphere **Z** has a charge of  $-7 \times 10^{-9} \text{ C}$ .

(2)

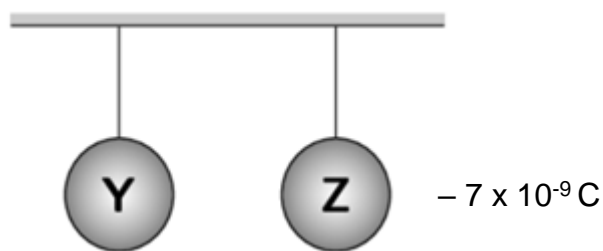

The spheres come into contact and then separate. The new charge on each sphere after separation is  $-5 \times 10^{-10} \text{ C}$ . Which of the following is the correct magnitude of charge on sphere **Y** before they touched?

- A  $+1,0 \times 10^{-8} \text{ C}$
- B  $+6 \times 10^{-9} \text{ C}$
- C  $-1,6 \times 10^{-19} \text{ C}$
- D  $-8 \times 10^{-9} \text{ C}$

(2)

- 1.5 After rubbing a polythene rod on the hair, a girl put the charged rod near a slow stream of water as shown below:

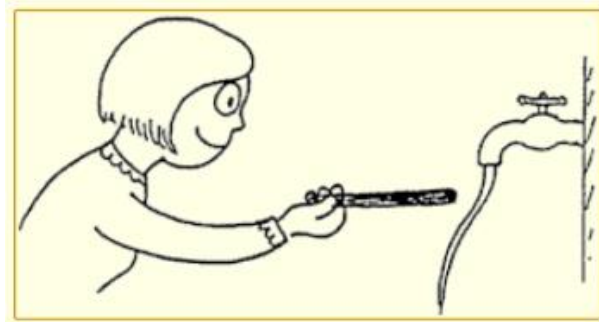

What conclusion can be deduced from the observation in the picture above?

- i The rod acquired electrons from rubbing against the hair.
- ii The net charge on the hair is negative after the rod is rubbed against it.
- iii Water has a dipole charge and the positive side of the dipole bends the water towards the charged rod.

Choose the CORRECT combinations:

- A i and ii
- B i, ii and iii
- C i and iii
- D ii and iii

(2)

- 1.6 Consider the circuit diagram below:

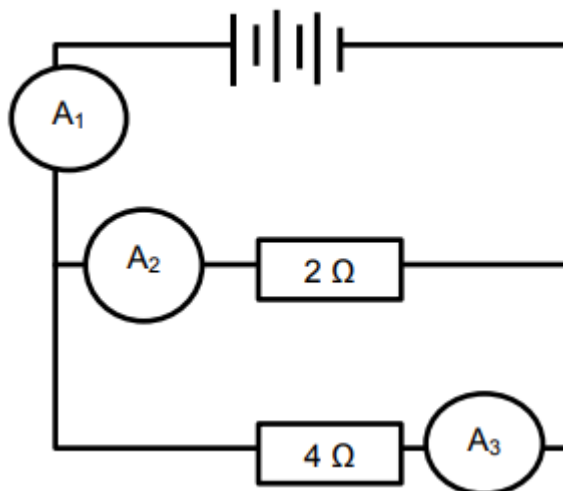

How will the readings on ammeters  $A_1$ ,  $A_2$  and  $A_3$  compare with each other?

- A  $A_1 = A_2 + A_3$
- B  $A_1 = A_2 = A_3$
- C  $(A_1 + A_2) < A_3$
- D  $A_2 < A_3 < A_1$

(2)

1.7 In the equation  $V_f = V_i + a \cdot \Delta t$ , the SI unit for  $a \cdot \Delta t$  is ....

- A m
- B  $m \cdot s^{-2}$
- C  $s^{-1}$
- D  $m \cdot s^{-1}$

(2)

1.8 Consider the velocity versus time graph for the motion of an object, below.

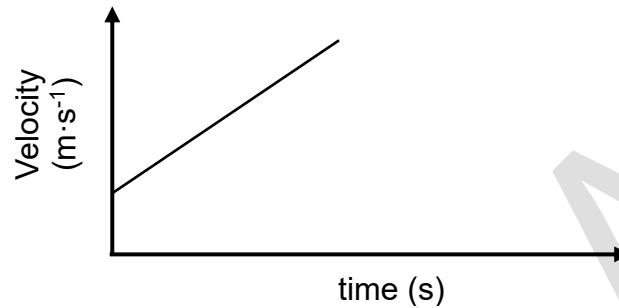

Which combination below, can be deduced about the acceleration in the above velocity-time graph?

- A Negative and increasing
- B Positive and decreasing
- C Positive and increasing
- D Positive and constant

(2)  
[16]

## QUESTION 2

- 2.1 The head-to-tail or tail-to-head method of representing vector diagrams is one of the most scientific methods used to calculate the resultant. Johnny moved from south to north for 4,5 km and then turned from north to west for 3 km.

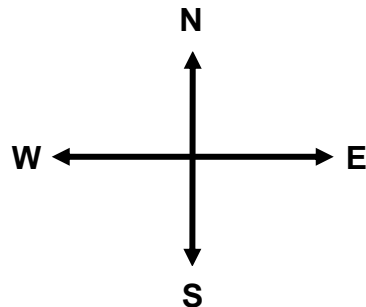

- 2.1.1 Define the term *scalar quantity*. (2)
- 2.1.2 Use the scale of **1,5 cm : 1 km** to draw the vector diagram and to calculate the resultant displacement of Johnny. (3)
- 2.1.3 Verify your answer using the theorem of Pythagoras to get the resultant displacement of Johnny in QUESTION 2.1.2. (4)
- 2.1.4 Is there any similarity between the solutions in QUESTION 2.1.2 and 2.1.3?  
Say Yes or No. Explain your observations. (2)
- 2.2 If Johnny decides to walk from south to north for 4,5 km and then turn from north to south for 3 km, write Johnny's:
- 2.2.1 Total distance (1)
- 2.2.2 Displacement (2)
- [14]**

### QUESTION 3

At a construction site, a crane accidentally drops a block of mass of 112 kg from a vertical height of 10 m above the ground as shown in the diagram below. Ignore the effects of air resistance.

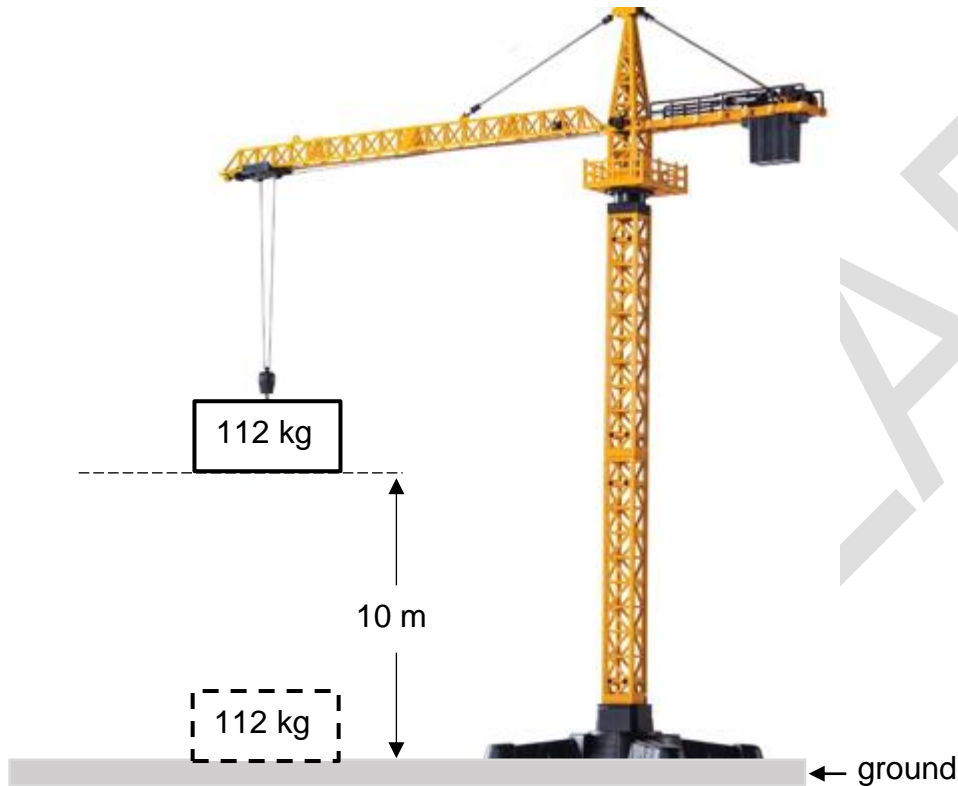

- 3.1 State the *law of conservation of mechanical energy* in words. (2)
- 3.2 Determine the gravitational potential energy of the block at height 10 m. (3)
- 3.3 Calculate the velocity of the block when it has fallen 2 metres. (4)
- 3.4 Prove, with calculations, that the velocity of the block is  $14 \text{ m}\cdot\text{s}^{-1}$  upon striking the ground. (4)
- 3.5 How will the mechanical energy change as the block is falling? Write only INCREASES, DECREASES or REMAINS THE SAME. Give a reason for your answer. (2)

**[15]**



### QUESTION 4

Two identical metal spheres are suspended on light, inelastic cotton threads. Sphere **T** carries a charge of  $+5,4 \text{ nC}$ . Sphere **S** carries a charge of  $-8,2 \text{ nC}$ .

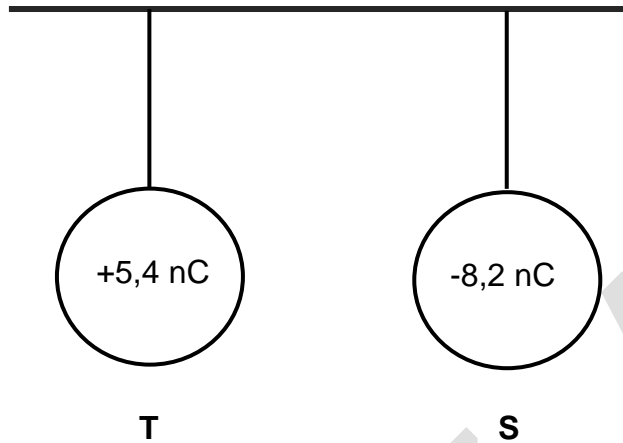

- 4.1 State the principle of *quantisation of charge*. (2)
- 4.2 Calculate the number of electrons added to sphere **S**. (3)
- 4.3 What type of force is exerted by sphere **S** on sphere **T**? (1)
- 4.4 The spheres are brought close to each other and then separated to their original positions.
- 4.4.1 From which sphere will electrons move, from (**T** to **S**) or (**S** to **T**)? (1)
- 4.4.2 State the *law of conservation of charge*. (2)
- 4.4.3 Use the law of conservation of charge to calculate the new charge on each sphere after separation. (3)
- 4.5 Use your knowledge of electrostatics to explain the phenomenon below:  
When the air is dry, your hands feel a small, sharp electric shock when you touch a metal doorknob after walking along the carpet to the door. (2)

[14]

**QUESTION 5**

**Circuit 1** and **Circuit 2** consist of a 12 V battery connected to a 24 Ω resistor and a light bulb with a resistance of 16 Ω.

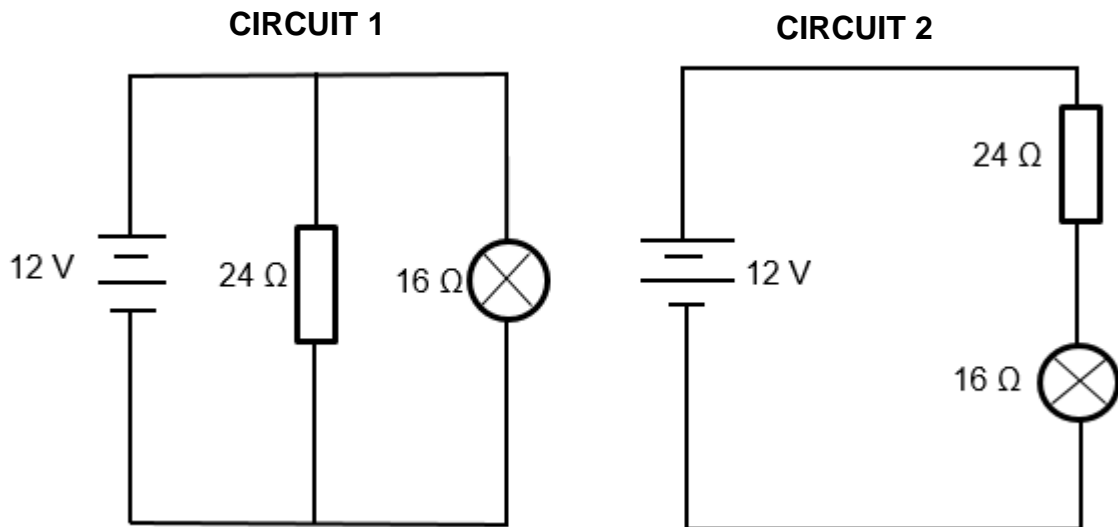

- 5.1 Define the term *emf*. (2)
- 5.2 Describe the arrangement of the resistor and light bulb in circuit 1. (1)
- 5.3 For **CIRCUIT 1**, calculate:
- 5.3.1 The equivalent resistance (3)
- 5.3.2 The current that passes through the light bulb (3)
- 5.4 For **CIRCUIT 2**, calculate:
- 5.4.1 The total resistance (2)
- 5.4.2 The current passing through the light bulb (2)
- 5.5 Calculate the charge that passes through the light bulb in circuit 2 when the current flows for 2 minutes. (3)
- 5.6 In which circuit (1 or 2) does the light bulb shine the brightest? Justify your answer. (3)

[19]

## QUESTION 6

Cars **A** and **B** are travelling in town where the speed limit is  $60 \text{ km}\cdot\text{h}^{-1}$ . The driver of **CAR B** stops at the traffic light. **CAR A** drove past **CAR B** at a constant velocity of  $77 \text{ km}\cdot\text{h}^{-1}$ . The driver of **CAR B** immediately reacted by accelerating his car from rest at  $1,5 \text{ m}\cdot\text{s}^{-2}$  for 6,5 seconds, chasing **CAR A**. After 6,5 seconds, **CAR B** continued driving with constant velocity.

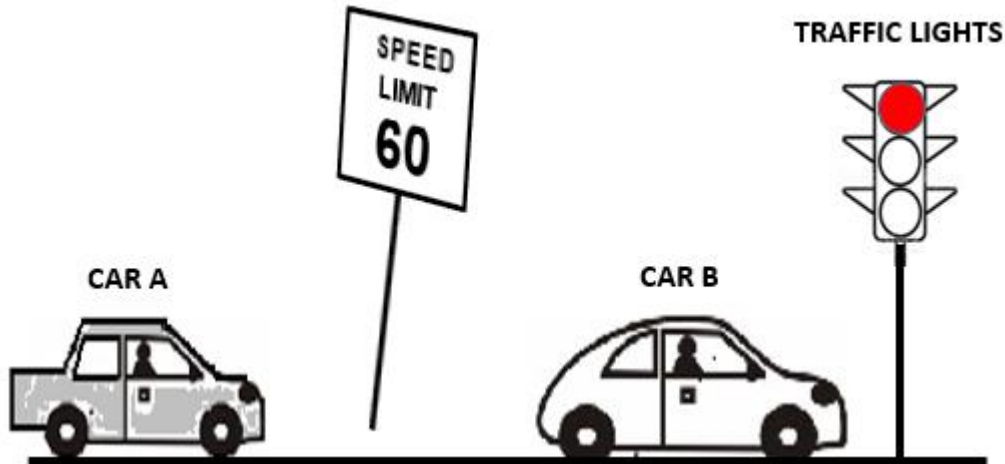

- 6.1 Define the term *acceleration*. (2)
- 6.2 Convert  $77 \text{ km}\cdot\text{h}^{-1}$  to  $\text{m}\cdot\text{s}^{-1}$ . (2)
- 6.3 Determine the velocity of **CAR B** while chasing **CAR A**. (4)
- 6.4 How far has **CAR B** driven after 6,5 seconds? (4)
- 6.5 How far did **CAR A** travel in that 6,5 seconds? (4)
- 6.6 Will **CAR B** be able to catch up with **CAR A**? Explain your answer. (4)
- The driver of **CAR A** suddenly hit the brakes and managed to stop after a distance 25 m. (2)
- 6.7 What acceleration does **CAR A** experience to come to a standstill after 2,5 s? (4)

[22]

**TOTAL: 100**

**END**

DATA FOR PHYSICAL SCIENCES GRADE 10  
PAPER 1 (CHEMISTRY)

GEGEWENS VIR FISIESTE WETENSAPPE GRAAD 10  
VRAESTEL 1 (CHEMIE)

TABLE 1: PHYSICAL CONSTANTS/TABEL 1: FISIESTE KONSTANTES

NAME/NAAM	SYMBOL/SIMBOOL	VALUE/WAARDE
Acceleration due to gravity <i>Swaartekragversnelling</i>	g	9,8 m·s <sup>-2</sup>
Speed of light in a vacuum <i>Spoed van lig in 'n vakuum</i>	c	3,0 x 10 <sup>8</sup> m·s <sup>-1</sup>
Planck's constant <i>Planck se konstante</i>	h	6,63 x 10 <sup>-34</sup> J·s
Charge on electron <i>Lading op elektron</i>	e	-1,6 x 10 <sup>-19</sup> C
Electron mass <i>Elektronmassa</i>	m <sub>e</sub>	9,11 x 10 <sup>-31</sup> kg

TABLE 2: FORMULAE/TABEL 2: FORMULES

MOTION/BEWEGING

$v_f = v_i + a\Delta t$	$\Delta x = v_i\Delta t + \frac{1}{2}a\Delta t^2$
$v_f^2 = v_i^2 + 2a\Delta x$	$\Delta x = \left(\frac{v_f + v_i}{2}\right)\Delta t$

WORK, ENERGY AND POWER/ARBEID, ENERGIE EN DRYWING

$U = mgh$ or/of $E_p = mgh$	$K = \frac{1}{2}mv^2$ or/of $E_k = \frac{1}{2}mv^2$
$E_M = E_k + E_p$ or/of $E_M = K + U$	

WAVES, SOUND AND LIGHT/GOLWE, KLANK EN LIG

$v = f\lambda$	$T = \frac{1}{f}$
$E = hf$ or/of $E = h\frac{c}{\lambda}$	

**ELECTROSTATICS/ELEKTROSTATIKA**

$n = \frac{Q}{e}$	$Q = \frac{Q_1 + Q_2}{2}$
-------------------	---------------------------

**ELECTRIC CIRCUITS/ELEKTRIESE STROOMBANE**

$Q = I \Delta t$	$\frac{1}{R_p} = \frac{1}{R_1} + \frac{1}{R_2} + \dots$
$R_s = R_1 + R_2 + \dots$	$V = \frac{W}{Q}$